

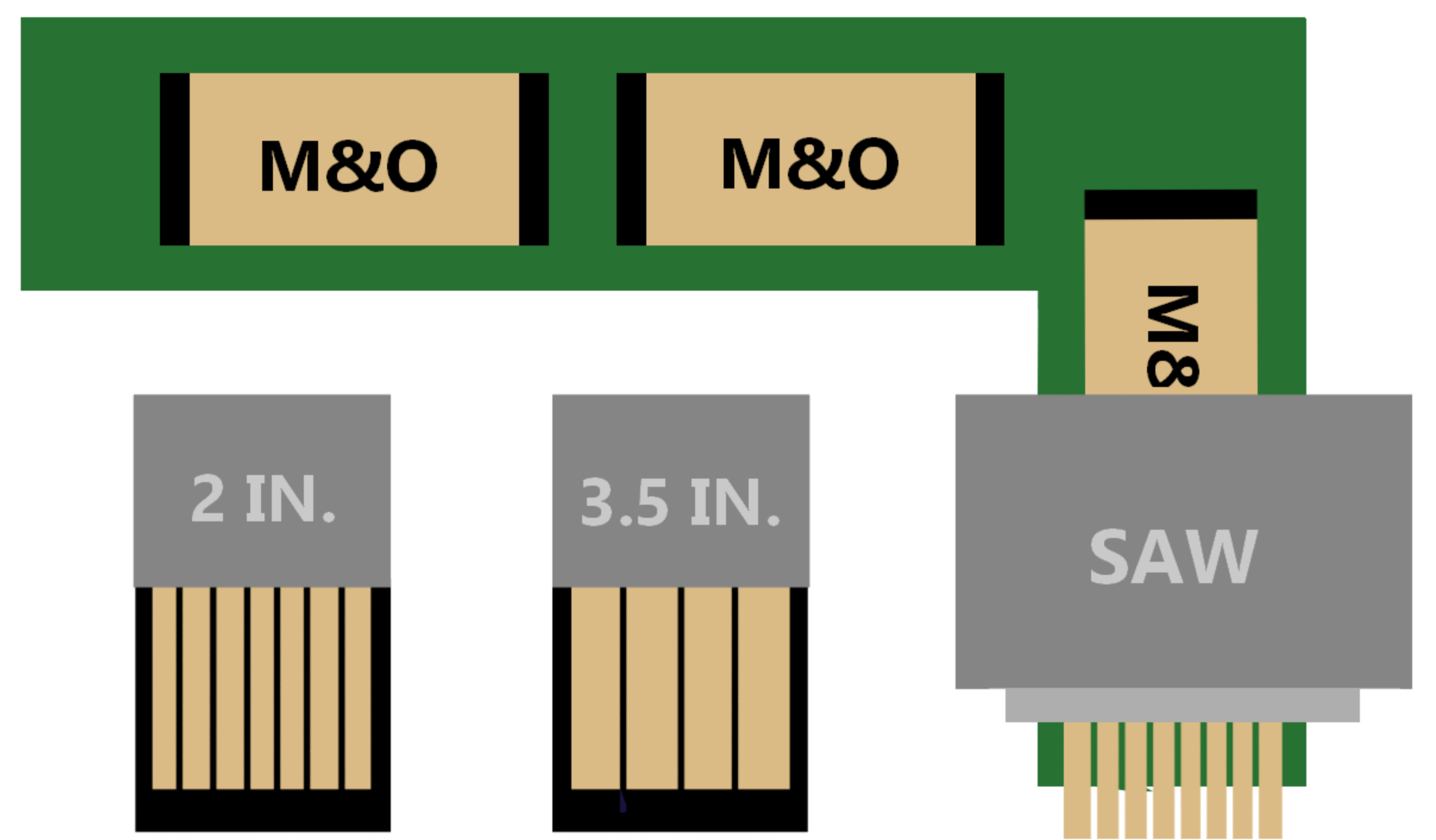

START: M&O and customer agree on prices and stocking levels of each item needed. The lumber ships into customer.

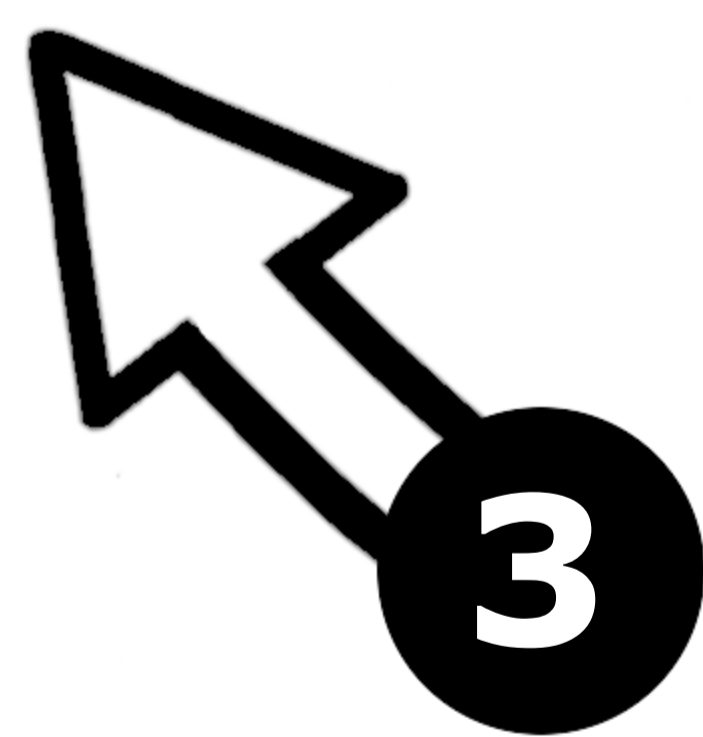

Customer uses desired packs of lumber and reports usage to M&O. All lumber that is used may sit un invoiced for a maximum of 90 days.

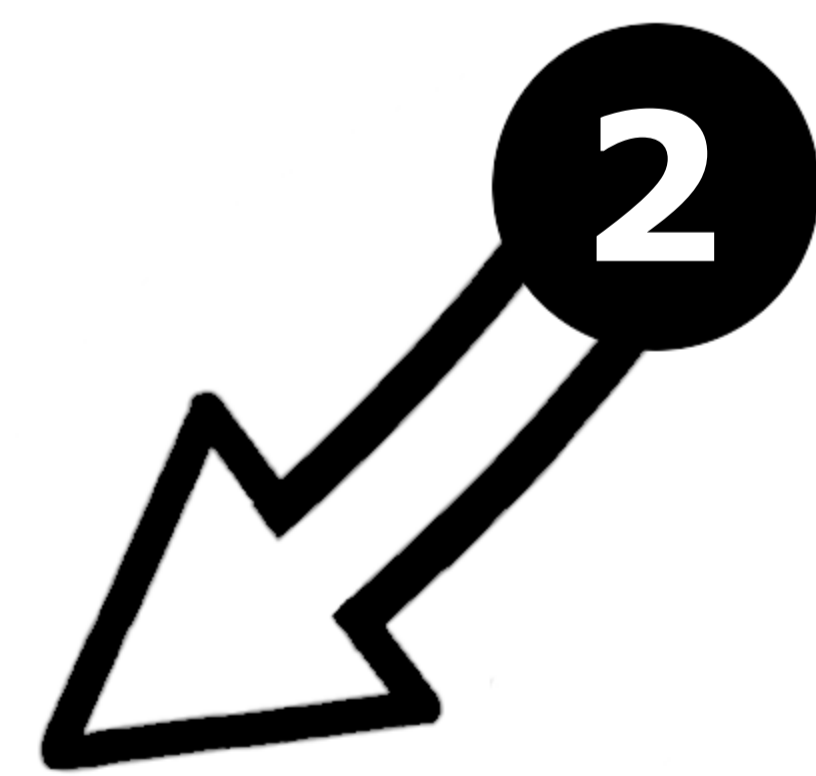

Once usage is reported to M&O, we start building your next order based on projected needs and lumber usage. M&O proactively communicates with customer to ensure customer has necessary inventory at all times.

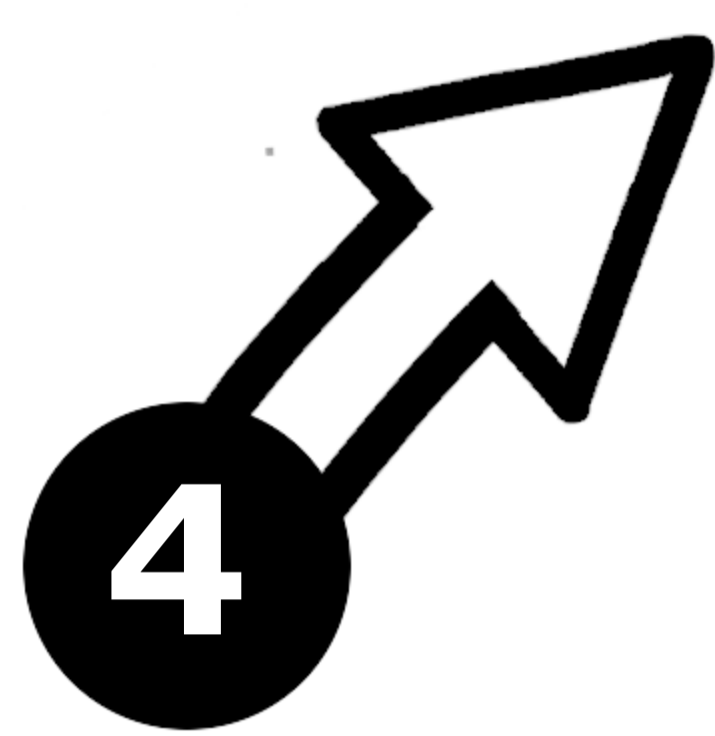
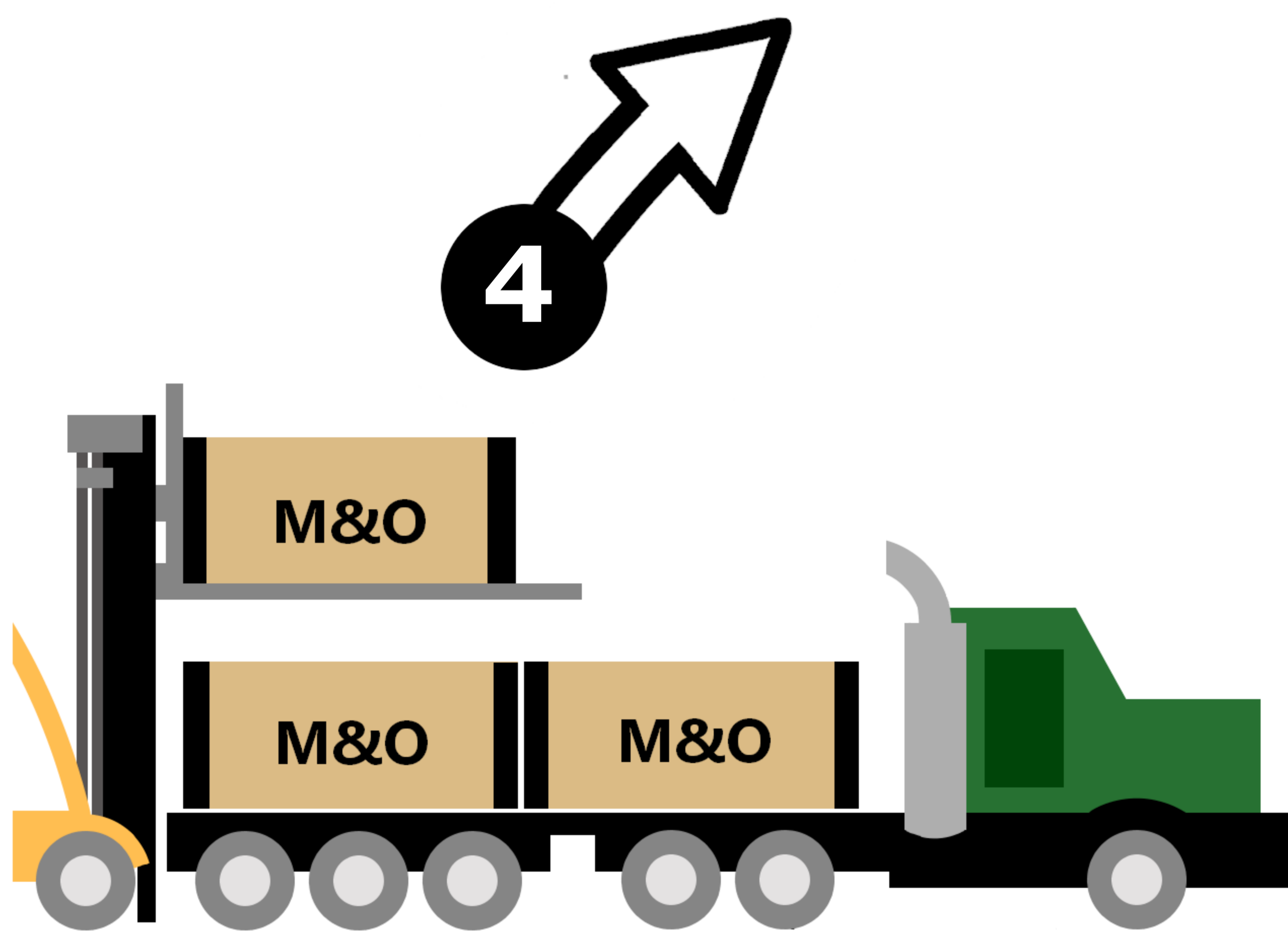

After the truck is built, we deliver to customer's door. M&O typically can predict customer needs farther ahead of time than customer because of the use of M&O's proprietary software.